

GLUBCO
DIVISION
OF
WEAPONRY



RAIL



GUN



Concept And Application

What is a railgun?

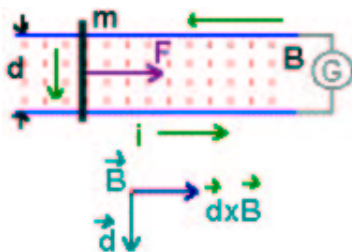

Railguns are electromagnetic launching devices based on the most fundamental concepts of electricity and magnetism. In short, Railguns are linear DC motors. The diagram to the left describes the forces which act upon current bearing objects in a magnetic field. With the field aligned perpendicular to the current (I) ninety degrees from the magnetic field (B). This means that mass (m) accelerates in a manner determined by the vector of the current.

- Physics is God's greatest miracle -

Therefore some things to keep in mind are:

Major Design Factors

1. Current between rails.
2. Rail length.
3. Flux density (B).
4. Width of armature (projectile).
5. Mass of armature.
6. Field direction consistency.

- B = Magnetic Flux
- i = current, arrows indicate current direction
- d = separation of rails
- m = mass of armature
- f = force
- a = f/m
- v = iBd
- Note: points indicate the presence of a vertical magnetic field.

*Number 6 refers to the use of magnets on top and bottom of the rails.

- Only evidence gives credence to theory -

Proof of Concept Railgun:

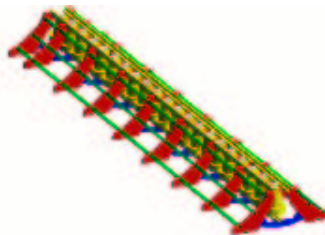
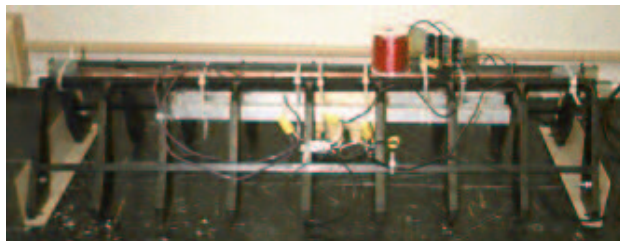

I recently tested a very small proof of concept railgun as a stepping stone to a larger machine. The POC model ran at 120VDC (both the rails and magnets in series with each other). Due to the very small scale of the project I only used four, homemade, soft iron core magnets each about 4" high and four windings thick. I used 18 gauge insulated wire for all windings. This provided slightly less than adequate resistance for the whole gun. A second inductive load consisting of 800 ft of 20 awg copper wire was placed above the rail to add resistance (3.5 Ohm) and to test high

speed protection diodes. This unit using only around 4" of active track flung a aluminum cylinder 1.5"x.5" around 5 m/s. Though no great accomplishment it gave a lot of insight into the following factors:

- Magnet distance below track: make this as close as possible.
- Track welding, at 15 amps this is a problem if the tracks are not powdered with graphite filings.
- Rail separation should be around 3/4" (i.e. a penny as a projectile)
- Magnets need to be pulsed according to position.

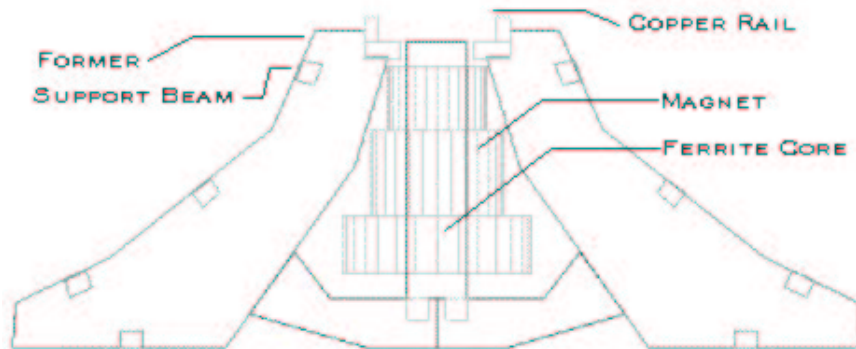

This cutaway view of the POC railgun shows the proper alignment of the rail in relationship to the coils. Also note the lack of magnets above the rail.



- Computers used to fill entire buildings -

What we have learned and what's next: *TRAP (Tabletop Railgun Acceleration Platform)*



The proof of concept railgun taught us some valuable lessons. The most important of these lessons is the need for a totally vertical field. This can be accomplished by placing magnets above and below the track. Another lesson is that of track welding, this can be prevented by lubricating the track with graphite and having a fast pre-injection speed. A final major improvement to be made is that of a moving field, or a switched array of coils.

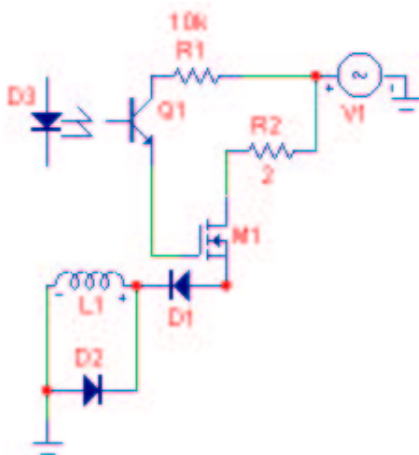

Basic protected high amp inductive load.

Switched coils means some type of solid state device is switching very high currents. This device happens to be a power FET (field effect transistor). Fets to carry 50 amps are readily available and easily paralleled. These switches will be powered up to 200 amps and optically isolated from the digital circuitry that controls them. The control boards consist of open gain op-amps connected to an array of infrared beam breaks spanning the length of the rail. These connect to counting, time based protection, and pulse length adjusting circuitry. Due to the overwhelming response to this page, I cannot offer any specific plans. If you have a rail-gun project and would like to contact me you can do so at seraphim@wpi.edu.

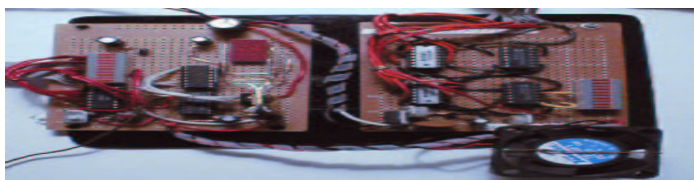

This is the infrared pulse counting circuit. Not shown is the eight sensor/emitter array which is also a structural member of the railgun. It is connected to the nine conductor cable on the upper right hand side of the boards. Open gain op-amps and inverting buffers clean

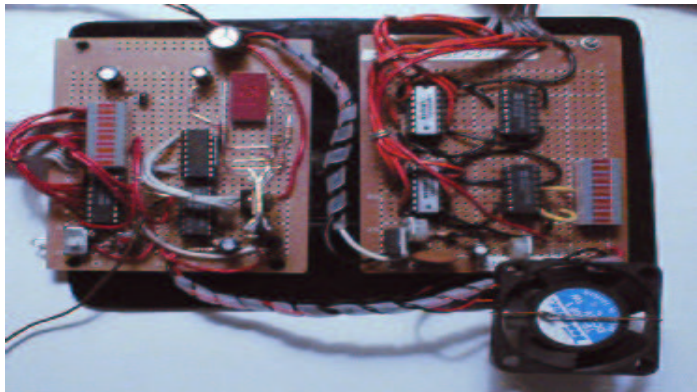

and detect the ir-transistor signal. The board on the left counts in decoded decade form and in four bit binary to supply a visual indication that a proper firing has occurred for up to 10 coils. The decade count is sent to an opto-isolation board.

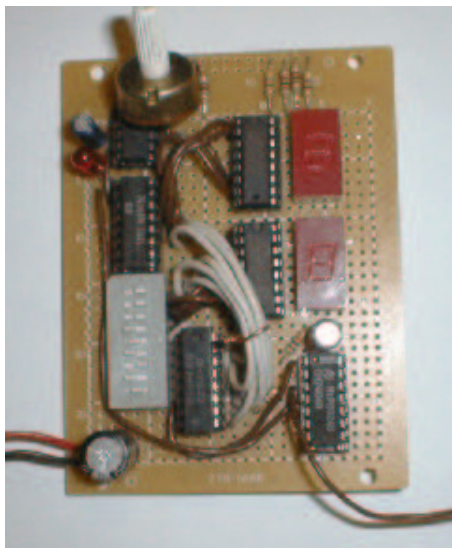

This circuit is perhaps the life-blood of the railgun. No high-power system is complete without a proper short protection system. If the projectile should weld to the track the system would quickly overheat and melt. To prevent this from happening all beam-break pulses are sent to this presettable 4-bit comparator. A 1/50 sec adjustable clock is fed through a presettable synchronous binary counter and compared to a preset number. Should the time between pulses exceed the preset time, failure is assumed and the system is shut down. Visual queues to both the preset number and the current count are displayed clearly on each board. Currently under development are pulse extension circuits adjustable for each coil.

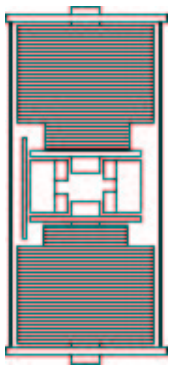

Top Coil

Rail Assembly

Bottom Coil

The projectile of choice for the new machine is a penny. This 3/4" copper disk is a good non-ferrous conductor that is fairly lightweight. It will fit in the the center gap of the all copper rail assembly between the top and bottom coils. The infrared sensor array runs down one side of the rail and the sensors are placed in 3/8" gaps between each magnet. The pre-injector for the gun is a five inch section of track with four unswitched magnets. A solenoid punch hits the penny down this section bringing it up to speed before entering the switched portion of the accelerator. A large capacitor is responsible for the injectors power.

- If people stop to watch, you're doing something right -

How you can help :

A word on railgun technology.



Military railguns are an advanced technology. They are also, however, an obscure technology. The electronic, mechanical, and mathematical complexities of railgun design do not lend them to the home experimenter. For this very reason, tabletop railgun platforms are a wonderful scientific challenge. The machine which is described on this page is not intended as a weapon, but rather as an experiment in mass driver technology. Propulsion without mechanical parts or expanding gasses is revolutionary in practice as well as in thought. It is a distinct possibility that future space launch systems will resemble railgun technology.

If you would like to support the continued development of this tabletop railgun in any way, do not hesitate to contact me at :

seraphim@wpi.edu



- If at first you do not succeed, increase the amperage -

Links to railguns that cost more than we'll ever have:

[Related railgun terms.](#)

[Electromagnetic Propulsion Homepage.](#)

[This link refers to a different form of railgun dealing with ultra high amps.](#)

[Parker Kinetic Designs Inc. High power supply solutions.](#)

[Center For Electromechanics, lots of info here on what's really going on.](#)

[Science Fair Railgun Study.](#)